

### ACCESSORY SOCKET

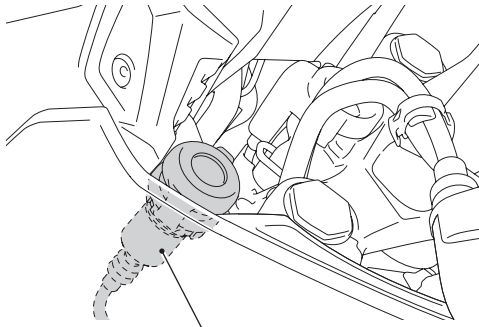

ACCESSORY SOCKET

- The maximum power rating of connected accessories is 36W (12V, 3A).
- Use accessories with engine running to avoid discharging the battery.
- Do not use a cigarette lighter, as this can cause a malfunction.
- Cover the socket with the cap when the accessory socket is not used to prevent entry of foreign objects.
- Do not use the accessory socket when the motorcycle is being washed.
- Carefully secure any connected devices, as vibrations may cause them to shift unexpectedly.
- Make sure that the cable of device connected to the accessory socket does not disturb the steering operation or riding. Do not pinch the cable to prevent from being damaged.

### DEFLECTOR

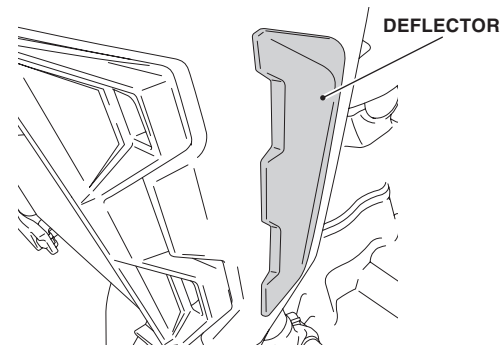

DEFLECTOR

- When this accessory becomes dirty, rinse it thoroughly with cool water to remove loose dirt, then wipe with a clean cloth or sponge. Do not use a brush to clean this accessory as it may scratch the surface.
- Never use organic solvents such as gasoline, thinner and benzene to clean this accessory. Also do not use acid or alkaline cleaners to clean this accessory. Wipe up spilled brake or battery fluid at once as they may damage the surface.

### FRONT SIDE PIPE

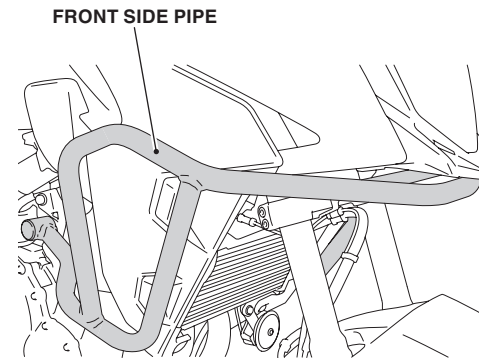

FRONT SIDE PIPE

- Do not attempt to move the motorcycle with holding front side pipe and also to apply extra pressure on them. It may damage the motorcycle and front side pipe.
- When this accessory becomes dirty, rinse it thoroughly with cool water to remove loose dirt, then wipe with a clean cloth or sponge. Do not use a brush to clean this accessory as it may scratch the surface.
- Never use organic solvents such as gasoline, thinner and benzene to clean this accessory. Also do not use acid or alkaline cleaners to clean this accessory. Wipe up spilled brake or battery fluid at once as they may damage the surface.

### CENTER STAND

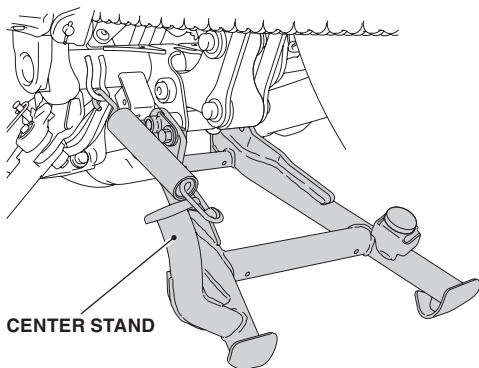

CENTER STAND

- Before starting your motorcycle, check that the side stand and the center stand are fully retracted.
- Always choose a flat ground when setting the center stand.

#### HOW TO USE THE CENTER STAND

1. Park safely on a level ground and stop the engine.
2. Setting the center stand.
  - Let down the center stand, stand on the left side of the motorcycle. Hold the left handle grip and the left grab rail or rear carrier. Press down on the tip of the stand with your right foot and, simultaneously, pull up and back.

### HEATED GRIPS

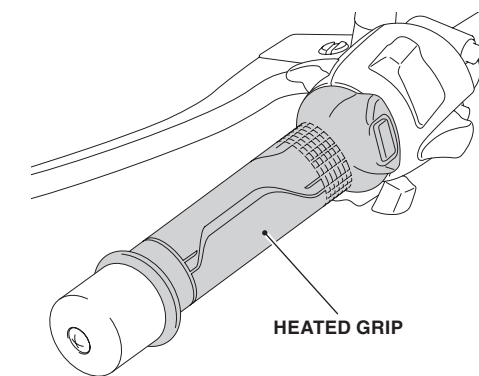

HEATED GRIP

#### HOW TO USE THE HEATED GRIP

- For operating instruction, refer to the Owner's Manual of the heated grip kit.

### KNUCKLE GUARD

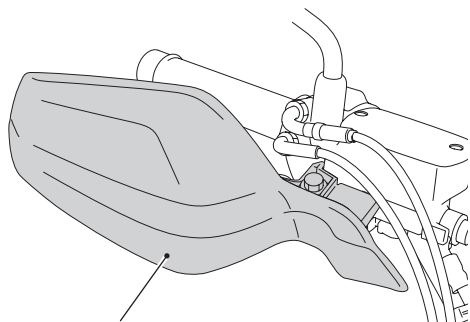

KNUCKLE GUARD

- When this accessory becomes dirty, rinse it thoroughly with cool water to remove loose dirt, then wipe with a clean cloth or sponge. Do not use a brush to clean this accessory as it may scratch the surface.
- Never use organic solvents such as gasoline, thinner and benzine to clean this accessory. Also do not use acid or alkaline cleaners to clean this accessory.  
Wipe up spilled brake or battery fluid at once as they may damage the surface.
- Handle this accessory with care. It can be damaged when it is bent excessively or is subject to strong shock or impact.

### REAR CARRIER A

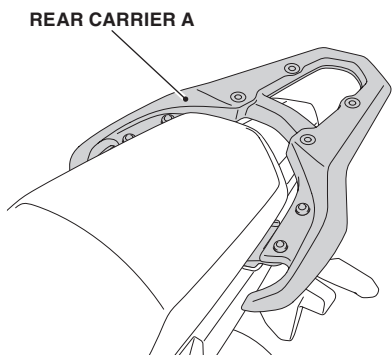

REAR CARRIER A

- The weight of the cargo must not exceed the following maximum load capacity:  
**6.6 lb (3.0 kg)**
- When this accessory becomes dirty, rinse it thoroughly with cool water to remove loose dirt, then wipe with a clean cloth or sponge. Do not use a brush to clean this accessory as it may scratch the surface.
- Never use organic solvents such as gasoline, thinner and benzine to clean this accessory. Also do not use acid or alkaline cleaners to clean this accessory.  
Wipe up spilled brake or battery fluid at once as they may damage the surface.

### REAR SEAT BAG

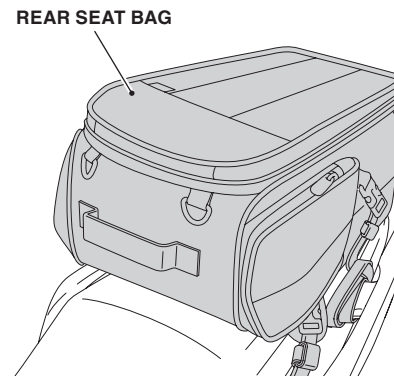

REAR SEAT BAG

- The weight of the cargo must not exceed the following maximum weight capacity:  
**8.8 lb (4.0 kg)**
- Be sure that the rear seat bag is installed securely before riding.
- Before riding, close the rear seat bag.
- The rear seat bag is not perfectly watertight, and water may enter when it rains, etc.
- Do not store valuables or fragile articles in the rear seat bag.
- To prevent burns, allow the engine, exhaust system, radiator, etc., to cool before installing and removing the accessory.
- When washing the motorcycle and when leaving the motorcycle, remove the rear seat bag.
- Do not let anybody ride on the rear seat bag and do not place luggage onto it.
- Never use organic solvents such as gasoline, thinner and benzine to clean this accessory. Also do not use acid or alkaline cleaners to clean this accessory.  
Wipe up spilled brake or battery fluid at once as they may damage the surface.

# CB500XA

## Genuine Accessory User's Guide

### HOW TO INSTALL THE REAR SEAT BAG

1. Install the rear seat bag as shown.

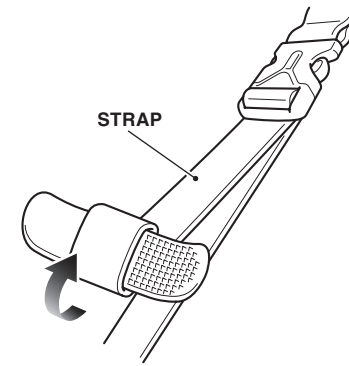
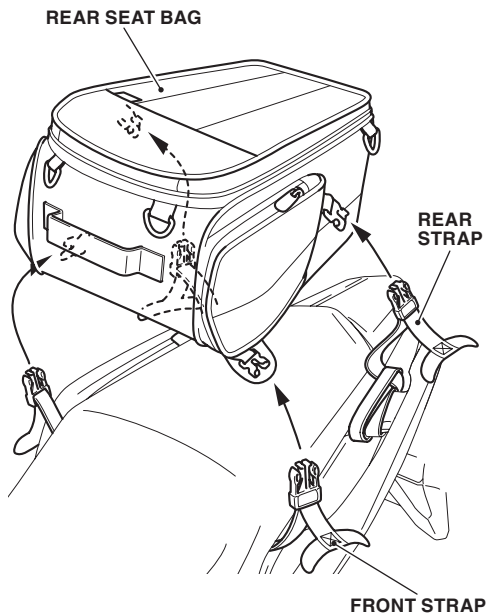

3. Wind the strap as shown.  
4. Secure the strap end as shown.

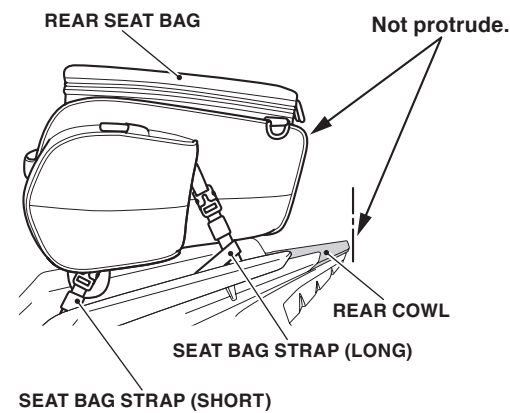
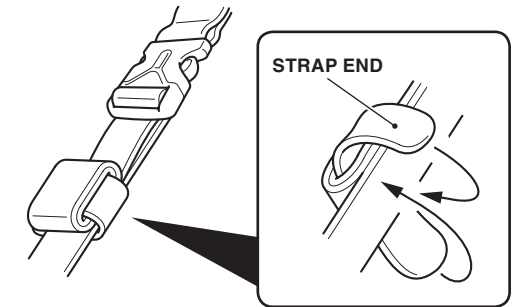

5. Secure the other straps in the same manner.  
6. Make sure that the rear seat bag does not protrude to the rear of the tail light as shown.  
• If the rear seat bag protrudes, adjust the tensions of front strap and rear strap.

REAR SEAT BAG

2. Tighten the straps while adjusting the balance between the right and left sides of the rear seat bag as shown.

- Repeat on the right side.
- Secure well by pulling the straps tight.

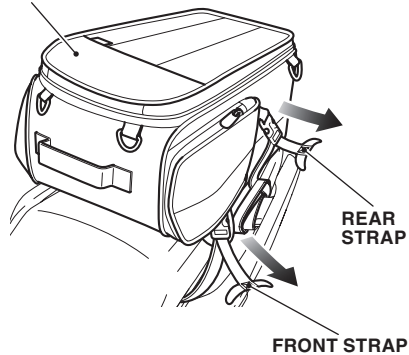

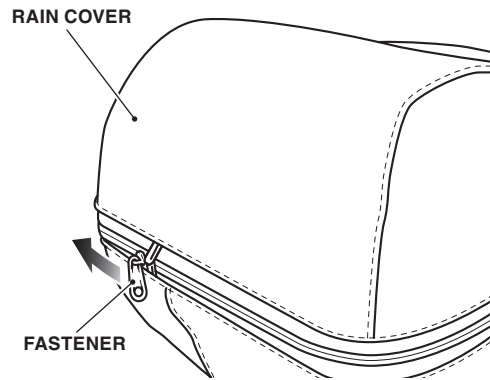

### HOW TO USE THE RAIN COVER

1. Open the fastener as shown.
  - Perform this step on extended the rear seat bag.

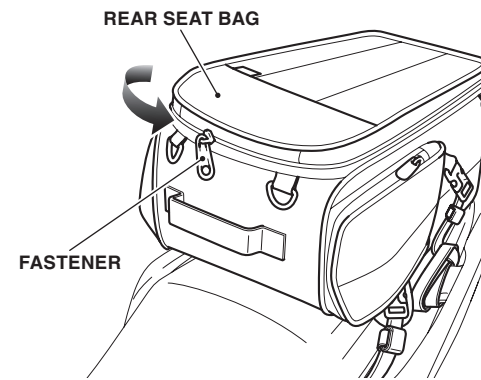

### HOW TO USE THE EXTENDED REAR SEAT BAG

1. Open the fastener as shown.

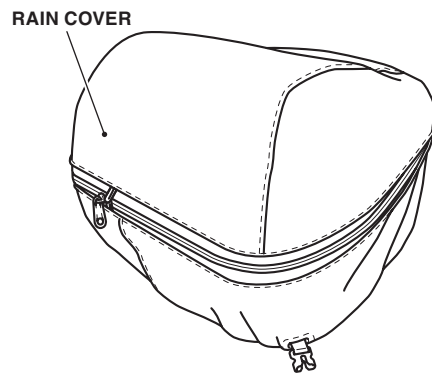

2. Temporarily release the buckles and pass them through the rain cover holes as shown.

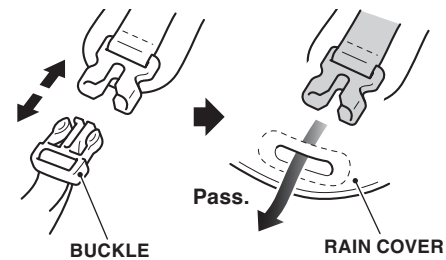

3. Cover the rain cover as shown.

4. Lock the buckles as shown.

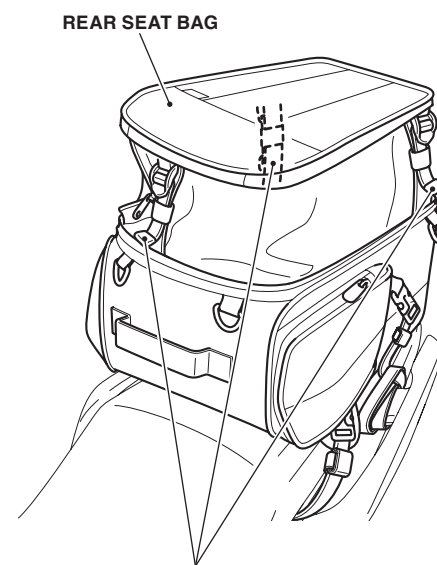
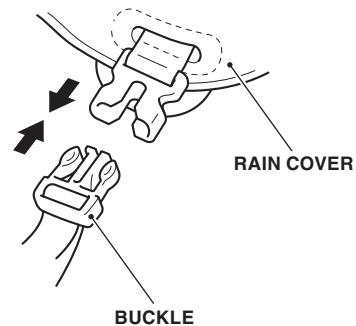

2. Pull up the rear seat bag as shown.

Firmly pull to secure the belts.

### REAR TRUNK

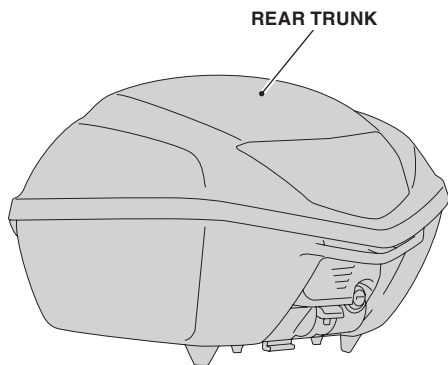

- The weight of the cargo must not exceed the following maximum weight capacity:  
**6.6 lb (3.0 kg)**
  - Be sure that the rear trunk is installed securely before riding.
  - Before riding, confirm that lid is closed and remove the key.
  - The rear trunk is not perfectly watertight, and water may enter when washing the motorcycle, when it rains, etc.
  - To prevent burns, allow the engine, exhaust system, radiator, etc., to cool before installing and removing the accessory.
  - Do not store valuables or fragile articles in the rear trunk.
  - Don't place a heavy object on the opened lid or apply an excessive force from the top of opened lid.
  - Open and close the lid gently.
  - If the rear trunk gets dirty, slightly push and clean it with a sponge or a shop towel moistened with a neutral detergent, remove the detergent with clean water, and then wipe them dry with a clean sponge or shop towel.
  - Never use organic solvents such as gasoline, thinner and benzine to clean this accessory. Also do not use acid or alkaline cleaners to clean this accessory.
- Wipe up spilled brake or battery fluid at once as they may damage the surface.

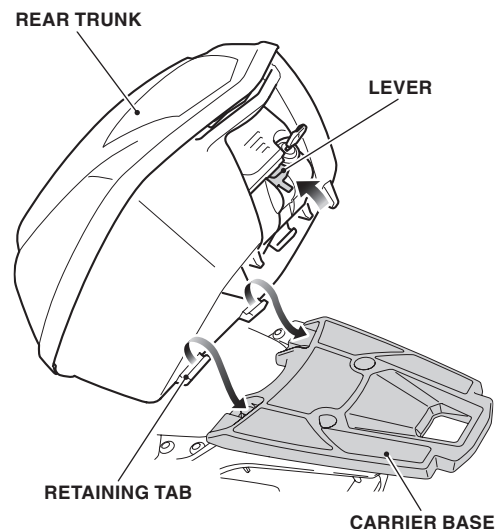

### HOW TO INSTALL THE REAR TRUNK

1. Insert the key and release the lock by turning the key clockwise.

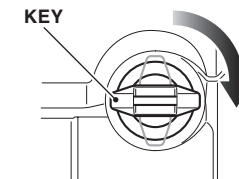

2. Lift the lever as shown, and insert the retaining tabs of rear trunk into the carrier base.

- Use the same procedures for other carrier base.

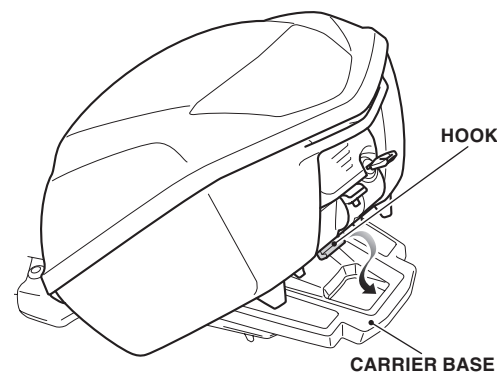

3. Position the hook on the carrier base as shown.

<HOOK POSITION>

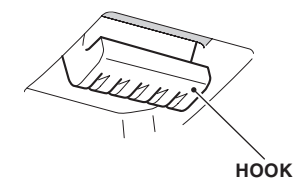

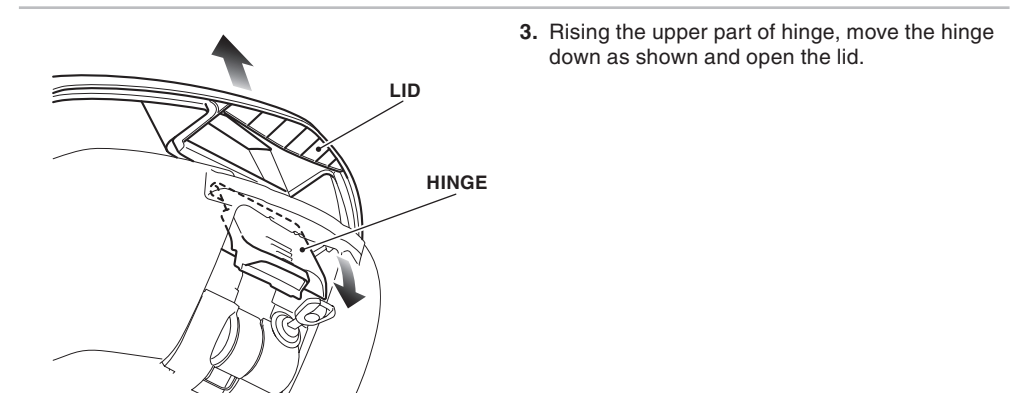
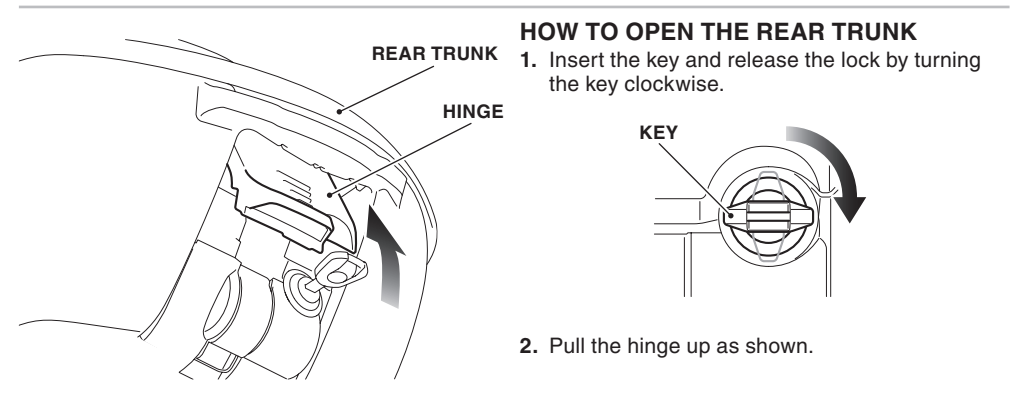
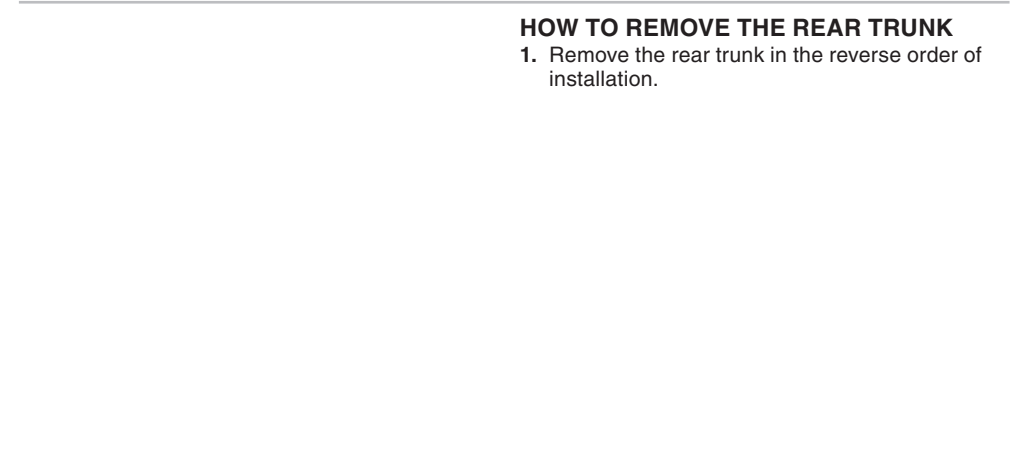
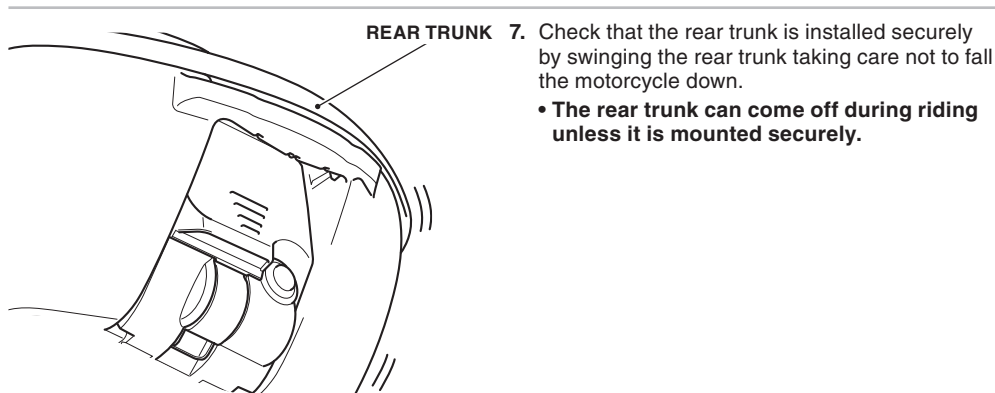
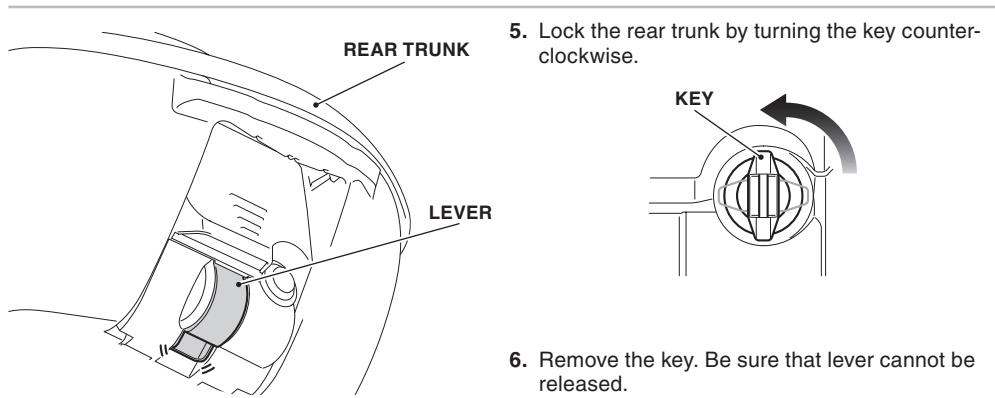
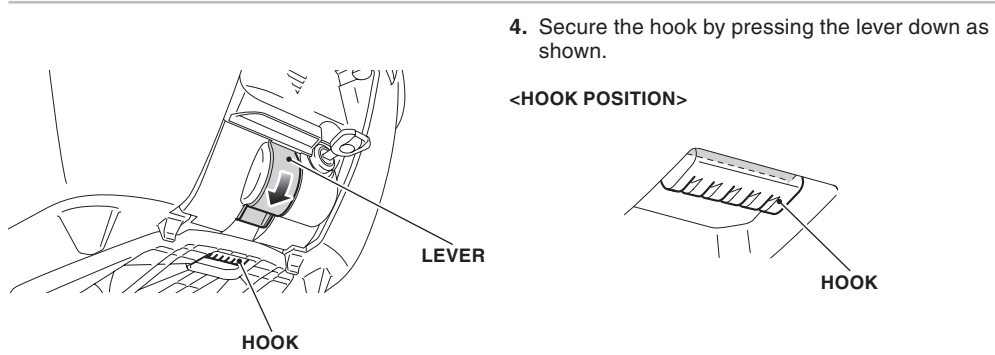

### HOW TO CLOSE THE REAR TRUNK

1. Confirm that the key position is as shown.

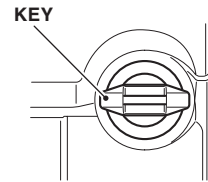

2. Close the lid.

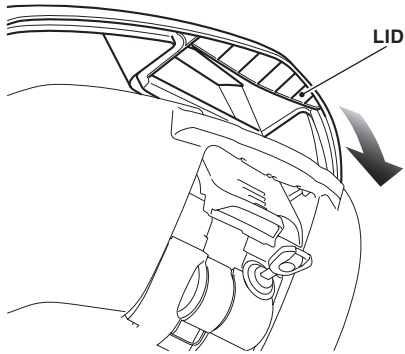

3. Holding the upper part of the hinge, push the hinge down.

- Be careful not to have the stored item pinched when the rear trunk is closed.

4. Lock the rear trunk by turning the key counter-clockwise.

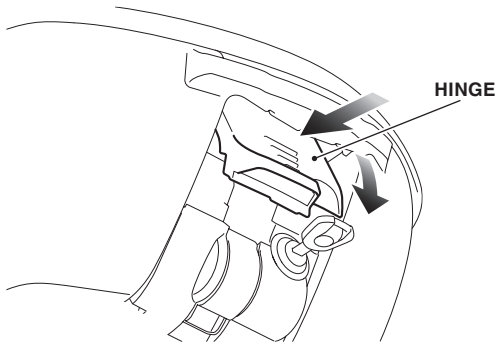
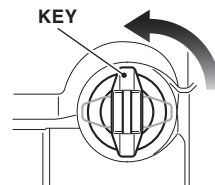

5. Remove the key.

- Make sure the lid and hinge are locked down securely.

### HOW TO STORE THE REAR TRUNK INNER BAG

1. Open the rear trunk and store the rear trunk inner bag.
2. Close the rear trunk.
  - Be careful not to have the stored item pinched when the rear trunk is closed.

### SADDLEBAG

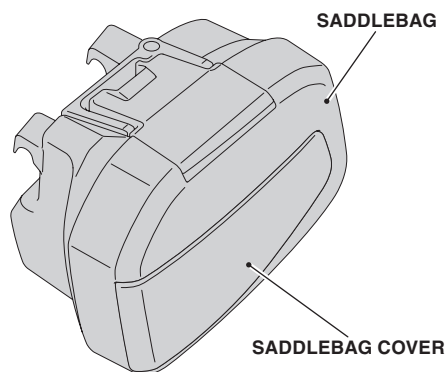

- The weight of the cargo must not exceed the following maximum weight capacity:  
**Each saddlebag 8.8 lb (4.0 kg)**
  - Load weight equally on both sides to minimize imbalance. If the weight is not loaded equally on both sides or if it exceeds the maximum weight capacity of this accessory, handling is proportionally affected, resulting in serious accident or injury.
  - Do not store valuables or fragile articles in the saddlebags.
  - Be sure that the saddlebags are installed securely before riding.
  - Before riding, confirm that lid is closed and remove the key.
  - To prevent burns, allow the engine, exhaust system, radiator, etc., to cool before installing and removing the accessory.
  - The saddlebag is hot while the engine is running and after it has been stopped (after riding etc.).
  - Especially the lower part of the saddlebag on the right side is close to the muffler and thus becomes very hot, for that reason it should not be touched for some time.
  - The saddlebags are not perfectly watertight, and water may enter when washing the motorcycle, when it rains, etc.
  - Always install saddlebags on both the left and the right side.
  - Don't place a heavy object on the opened lid or apply an excessive force from the top of opened lid.
  - Open and close the lid gently.
  - If the saddlebag gets dirty, slightly push and clean it with a sponge or a shop towel moistened with a neutral detergent, remove the detergent with clean water, and then wipe them dry with a clean sponge or shop towel.
  - Never use organic solvents such as gasoline, thinner and benzine to clean this accessory. Also do not use acid or alkaline cleaners to clean this accessory.
- Wipe up spilled brake or battery fluid at once as they may damage the surface.

### HOW TO INSTALL THE SADDLEBAGS

1. Install the key and release the lock by turning the key clockwise.

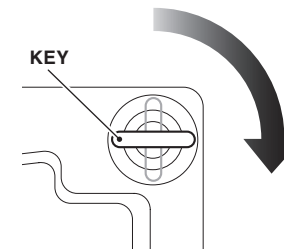

2. Raise the handle lever as shown, and install the saddlebag.

- Insert into the hook.

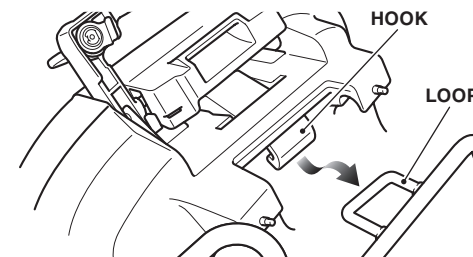
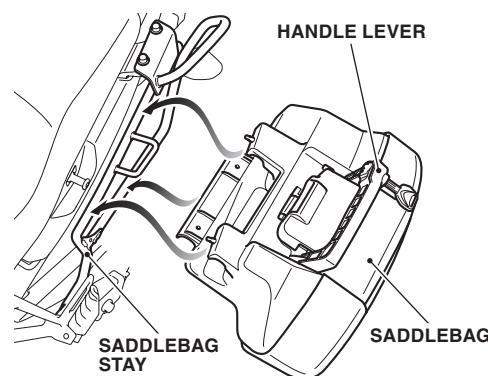

3. Lower the handle lever as shown.
4. Lock the saddlebag by turning the key counter-clockwise.

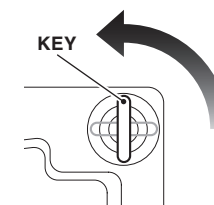
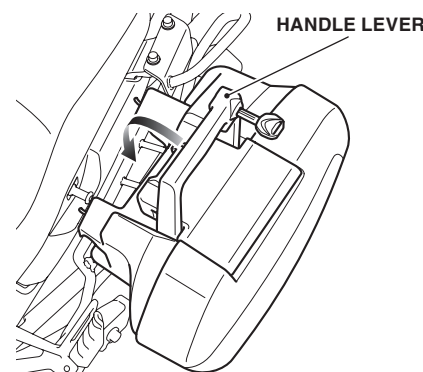



# CB500XA

## Genuine Accessory User's Guide

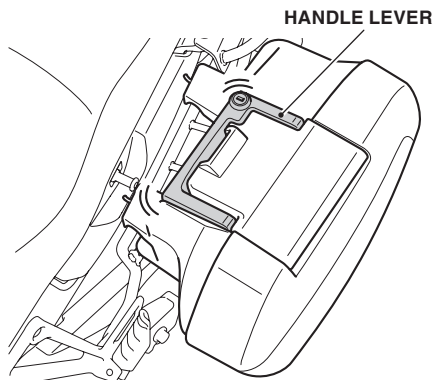

5. Remove the key. Be sure that the handle lever cannot be released.

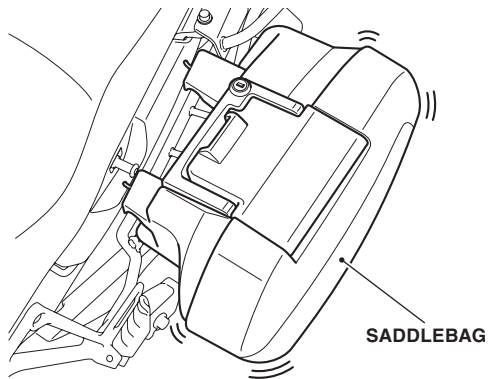

6. Check that the saddlebag is installed securely by swinging the saddlebag taking care not to fall the motorcycle down.
- **The saddlebag can come off during riding unless it is mounted securely.**

### HOW TO REMOVE THE SADDLEBAGS

1. Remove the saddlebags in the reverse order of installation.

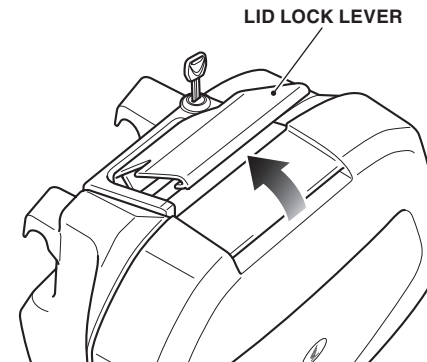

### HOW TO OPEN THE SADDLEBAGS

1. Install the key and release the lock by turning the key clockwise.

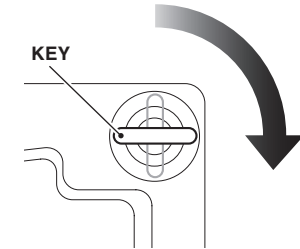

2. Lift the lid lock lever as shown.

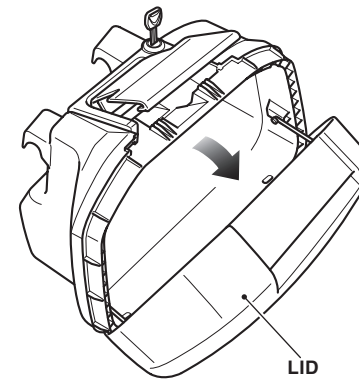

3. Open the lid as shown.

### HOW TO CLOSE THE SADDLEBAGS

1. Close the saddlebags in reverse order of opening.
- **Be careful not to have the stored item pinched when the saddlebag is closed.**

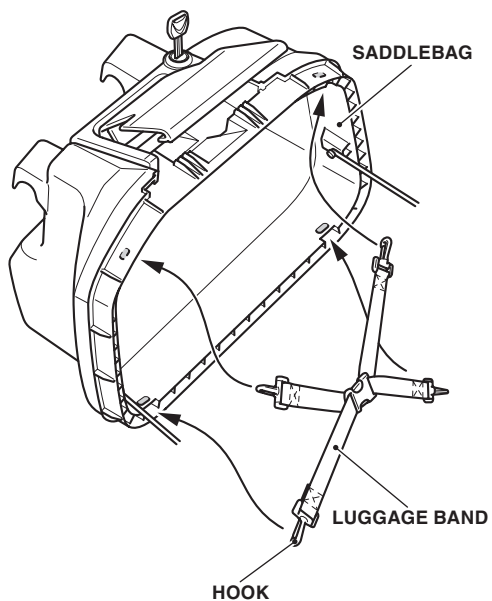

### HOW TO INSTALL THE LUGGAGE BAND

1. Open the lid.
2. Install the luggage band as shown.
  - Secure the hooks to the shaded parts.

### TANK BAG

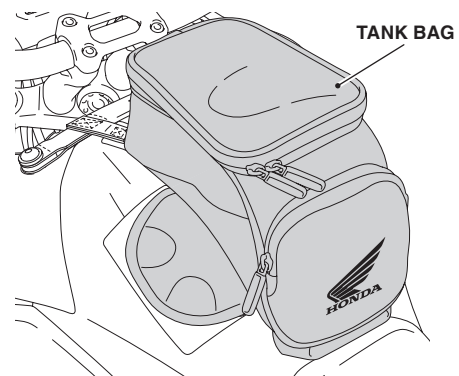

- The weight of the cargo must not exceed the following maximum weight capacity:  
**Tank bag 3.3 lb (1.5 kg)**
  - Be sure that the tank bag is installed securely before riding.
  - Before riding, close the tank bag.
  - The tank bag is not perfectly watertight, and water may enter when it rains, etc.
  - Do not store valuables or fragile articles in the tank bag.
  - When washing the motorcycle and when leaving the motorcycle, remove the tank bag.
  - Before installation, remove all dust, sand, etc. from fuel tank and tank bag, as otherwise the fuel tank may be damaged.
  - Never use organic solvents such as gasoline, thinner and benzine to clean this accessory. Also do not use acid or alkaline cleaners to clean this accessory.
- Wipe up spilled brake or battery fluid at once as they may damage the surface.

### HOW TO INSTALL THE TANK BAG

1. Lock the buckle as shown.
  - Repeat on the right side.

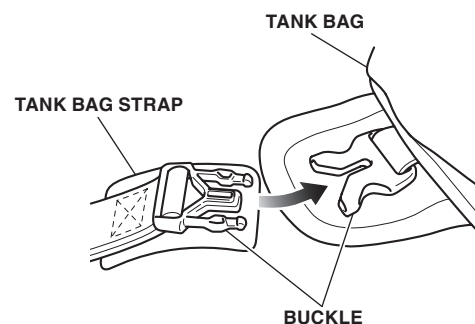

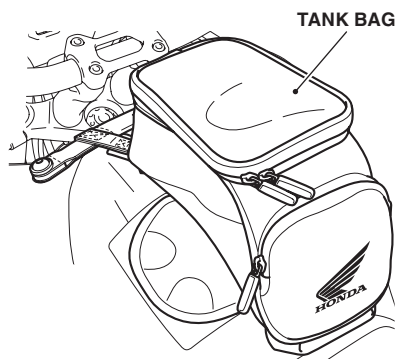

2. Install the tank bag as shown.

### HOW TO USE THE TANK BAG COVER

1. Put the tank bag cover on the tank bag.

### WHEEL STRIPE

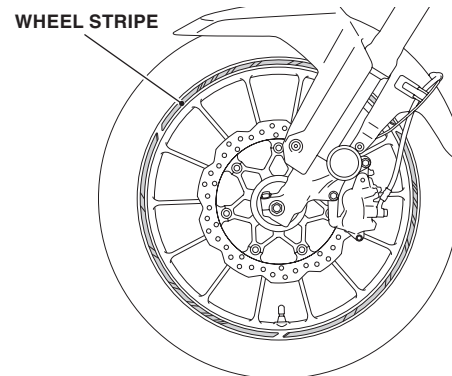

- When this accessory becomes dirty, rinse it thoroughly with cool water to remove loose dirt, then wipe with a clean cloth or sponge. Do not use a brush to clean this accessory as it may scratch the surface.
- Never use organic solvents such as gasoline, thinner and benzine to clean this accessory. Also do not use acid or alkaline cleaners to clean this accessory. Wipe up spilled brake or battery fluid at once as they may damage the surface.
- Do not wash the motorcycle with a high-pressure washer, as this may peel off the wheel stripes.

### TANK PAD

for USA

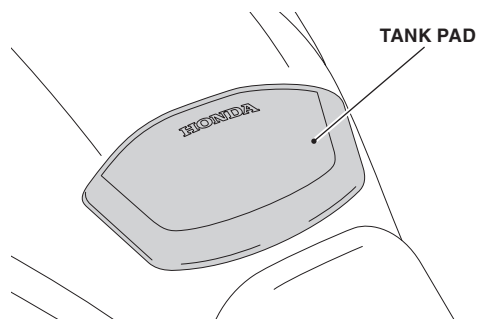

- When this accessory becomes dirty, rinse it thoroughly with cool water to remove loose dirt, then wipe with a clean cloth or sponge. Do not use a brush to clean this accessory as it may scratch the surface.
- Never use organic solvents such as gasoline, thinner and benzine to clean this accessory. Also do not use acid or alkaline cleaners to clean this accessory. Wipe up spilled brake or battery fluid at once as they may damage the surface.